

Nice RunKit

For sliding gates weighing up to 1800 kg (RUN1800) and up to 2500 kg (RUN2500). Electromechanical gear motor with Nice BlueBUS technology.

Ventilated motor with inductive limit switch (RUN1800P/RUN2500P) or electromechanical limit switch (RUN1800/RUN2500I/RUN2500). Suitable to operate in extreme conditions, in systems for intensive use.

Simple to install: the BlueBUS system enables connections by means of just two wires between the control unit and up to 15 control safety and signalling devices.

Safe: the acceleration settings (at the start of the manoeuvre) and the deceleration settings (at the end of the manoeuvre) are precise and reliable.

The temperature sensor: Run is able to manage force, adapting it to the different climatic and environmental conditions, while adapting the thermal cut-out protection and intensity of self-ventilation, depending on the temperature reading. A **master/slave selection** also automatically synchronises 2 motors, enabling the automation of sliding gates with two opposing leaves.

Practical and functional: the control unit and inverter, housed inside Run, can be simply connected by means of the practical connector guide.

Very quiet: gear motor on bearings.

Version with built-in inverter (RUN2500I)

The **inverter** enables power supply and activation of the 3-phase motor with single phase 230 Vac current. It also enables variation of the automation speed by simply adjusting the frequency, settable from a minimum of **8.2 m/min** to a **maximum of 15.4 m/min**, to optimise the work load and system performance.

Perfect movement: in the automation deceleration phase, the inverter, which dialogues with the control unit, increases the torque, thus improving performance and reducing the risk of the automation blocking on impact with obstacles. The acceleration settings (at the start of the manoeuvre) and the deceleration settings (at the end of the manoeuvre) are precise and reliable.

The **built-in control unit automatically adjusts** the manoeuvre speed on the basis of the **gate weight** (calculated by measuring the force required for the movement), simplifying the operations for checking and ensuring compliance of the automation with standards.



Technical specifications		RUN1800/1800P	RUN2500/2500P	RUN2500I
Power	(Vac)	230		
Max. powered absorbed	(VA)	700	850	650
Current absorbed (line)	(A)	3	3.7	2.8
Protection level	(IP)	44		
Torque	(Nm)	20	25	
Max. thrust	(N)	1100	1390	1670
Max. torque	(Nm)	40	50	60
Speed	(m/min.)	10		8.2 ÷ 15.4
Max. gate weight	(kg)	1800	2500	
Working temp.	(C° Min/Max)	-20 ÷ +50		
Insulation class		1		
Max work cycle *	(cycles/hour)	10	24	28
Dimensions	(mm)	400x387x253		
Weight	(kg)	24.5		25

Dimensions

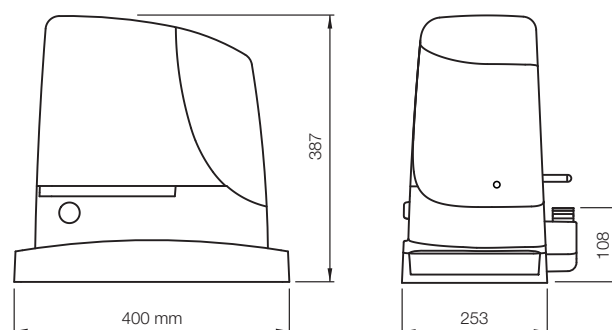

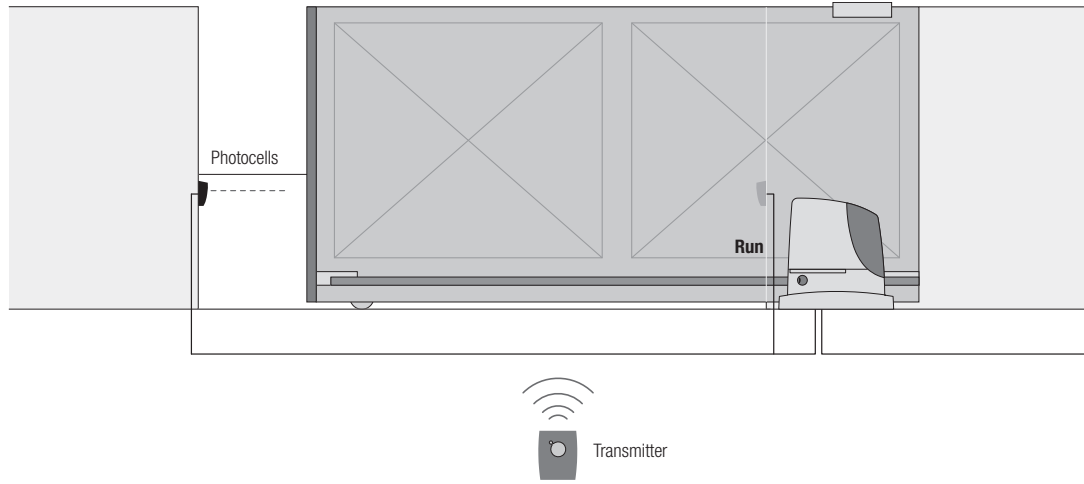
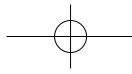

Product in details



The strongest model for sliding gates equipped with BlueBUS technology: strong, intelligent and safe, adding unrivalled installation simplicity to the traditional features of Nice.

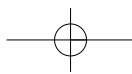

Nice RunKit

For sliding gates weighing up to 1800 kg

RunKit 1

With BlueBUS technology, including:



RUN1800

irreversible
electromechanical
gear motor, with
incorporated control unit,
with electromechanical
limit switch,
for gates up to 1800 kg
1 pc

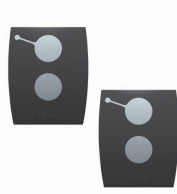

ON2

two transmitters
433.92 MHz,
2 channels
2 pcs



MOFB

one couple of outdoor
photocells designed
for connection
via Nice BlueBUS
1 pc



OXI

receiver up to 4 channels
with connector, without
built-in transmitter
1 pc

Nice Price **£ 982.00**

RunKit 2

With BlueBUS technology, including:



RUN1800P

irreversible
electromechanical
gear motor, with
incorporated control unit,
with inductive limit switch,
for gates up to 1800 kg
1 pc

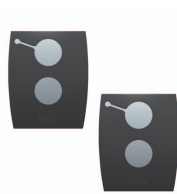

ON2

two transmitters
433.92 MHz,
2 channels
2 pcs



MOFB

one couple of outdoor
photocells designed
for connection
via Nice BlueBUS
1 pc



OXI

receiver up to 4 channels
with connector, without
built-in transmitter
1 pc

Nice Price **£ 1,041.00**

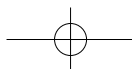

For sliding gates weighing up to 2500 kg

RunKit 3

With BlueBUS technology, including:



RUN2500

irreversible
electromechanical
gear motor, with
incorporated control unit,
with electromechanical
limit switch,
for gates up to 2500 kg
1 pc

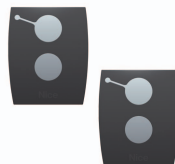

ON2

two transmitters
433.92 MHz,
2 channels
2 pcs



MOFB

one couple of external
photocells designed
for connection
via Nice BlueBUS
1 pc



OXI

receiver up to 4 channels
with connector, without
built-in transmitter
1 pc

Nice Price £ 1,067.00

RunKit 4

With BlueBUS technology, including:



RUN2500P

irreversible
electromechanical
gear motor, with
incorporated control unit,
with inductive limit switch,
for gates up to 2500 kg
1 pc

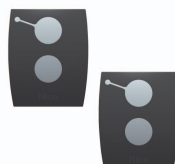

ON2

two transmitters
433.92 MHz,
2 channels
2 pcs



MOFB

one couple of outdoor
photocells designed
for connection
via Nice BlueBUS
1 pc



OXI

receiver up to 4 channels
with connector, without
built-in transmitter
1 pc

Nice Price £ 1,128.00

RunKit 5

With Nice BlueBUS technology and built-in inverter, including:



RUN2500I

irreversible
electromechanical
gear motor, with built-in
control unit and inverter,
electromechanical limit
switches, for gates
up to 2500 kg

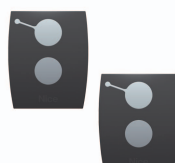

ON2

two transmitters
433.92 MHz,
2 channels
2 pcs



MOFB

one couple of outdoor
photocells designed
for connection
via Nice BlueBUS
1 pc



OXI

receiver up to 4 channels
with connector, without
built-in transmitter
1 pc

Nice Price £ 1,312.00

