

READYMADE RAILING

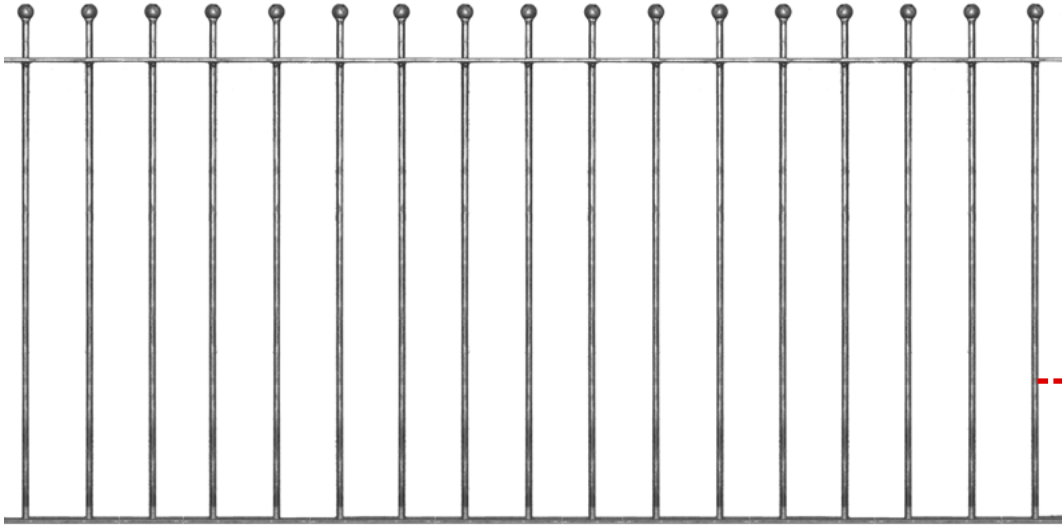

Product Code:
RAIL 1
956 mm
finished height

*Single Bars
available in the
Decorative Bar
Section*

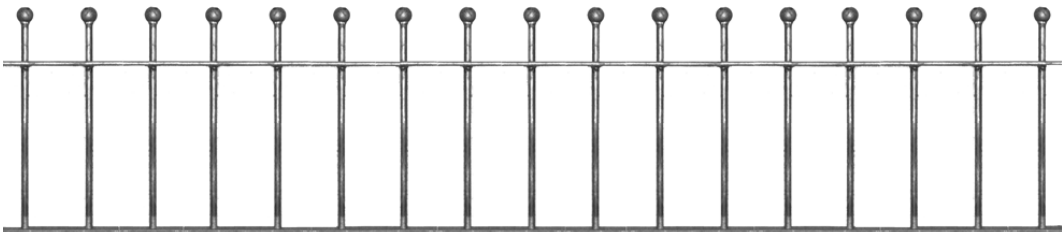

Product Code:
RAIL 2
450 mm
finished height

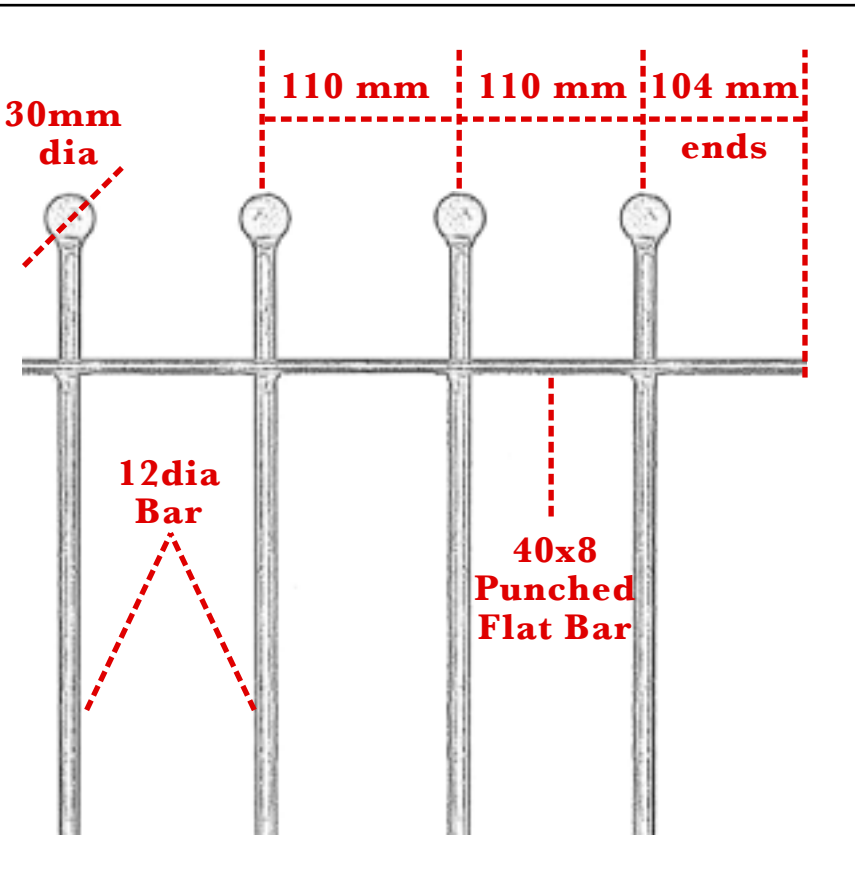

These readymade railings are made to order and require 3-5 days to manufacture.

The two standard finished lengths in which they are available, are:

- a) 956 mm, and
- b) 450 mm

The standard length of these railings is 1968 mm.

Railings with customised lengths could be manufactured depending upon the size of the order.

For latest prices and custom orders, please call our sales team on 0114 244 9663

Description	Price per item	Primed with Red Oxide
50 x 50 RHS Post with 50 mm Postcap having a 50mm sphere or flat plastic cap Fixing lug = 40 x 40 mm with 30 x 12 mm slot		

50 Ø Postcap or Plastic Cap

Lug Styles

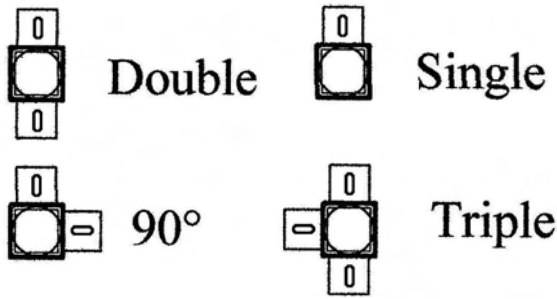

Fixing Lug

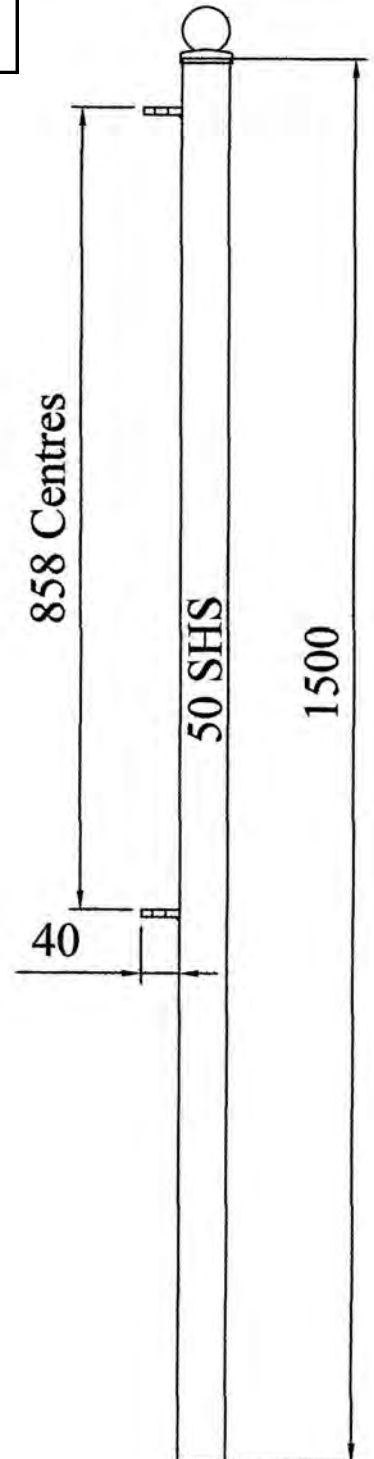
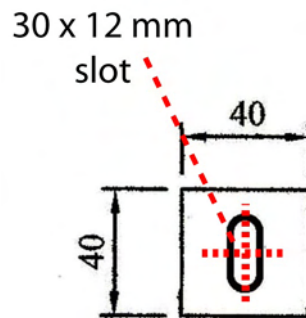

Creating your Readymade Panel Package:

Step 1 : Select a readymade panel design from the options shown in the following pages

Step 2 : Choose to have them either in self colour or primed with red oxide.

Step 3 : Select a Post by deciding on the number/style of fixing lugs you would like it to have.

All different post options cost the same. Also, if you have chosen to have your panels primed, the posts come primed free of charge.

Step 4 : Determine the quantity of panels / posts required and based on the pricing information on the relevant pages, add up the figures for the total cost of your order.

Custom heights from 400mm to 1500mm are available in these panels. To discuss your requirements in detail please contact our sales team.

Please note: These panels are not a stock item and require 5-7 days to manufacture.

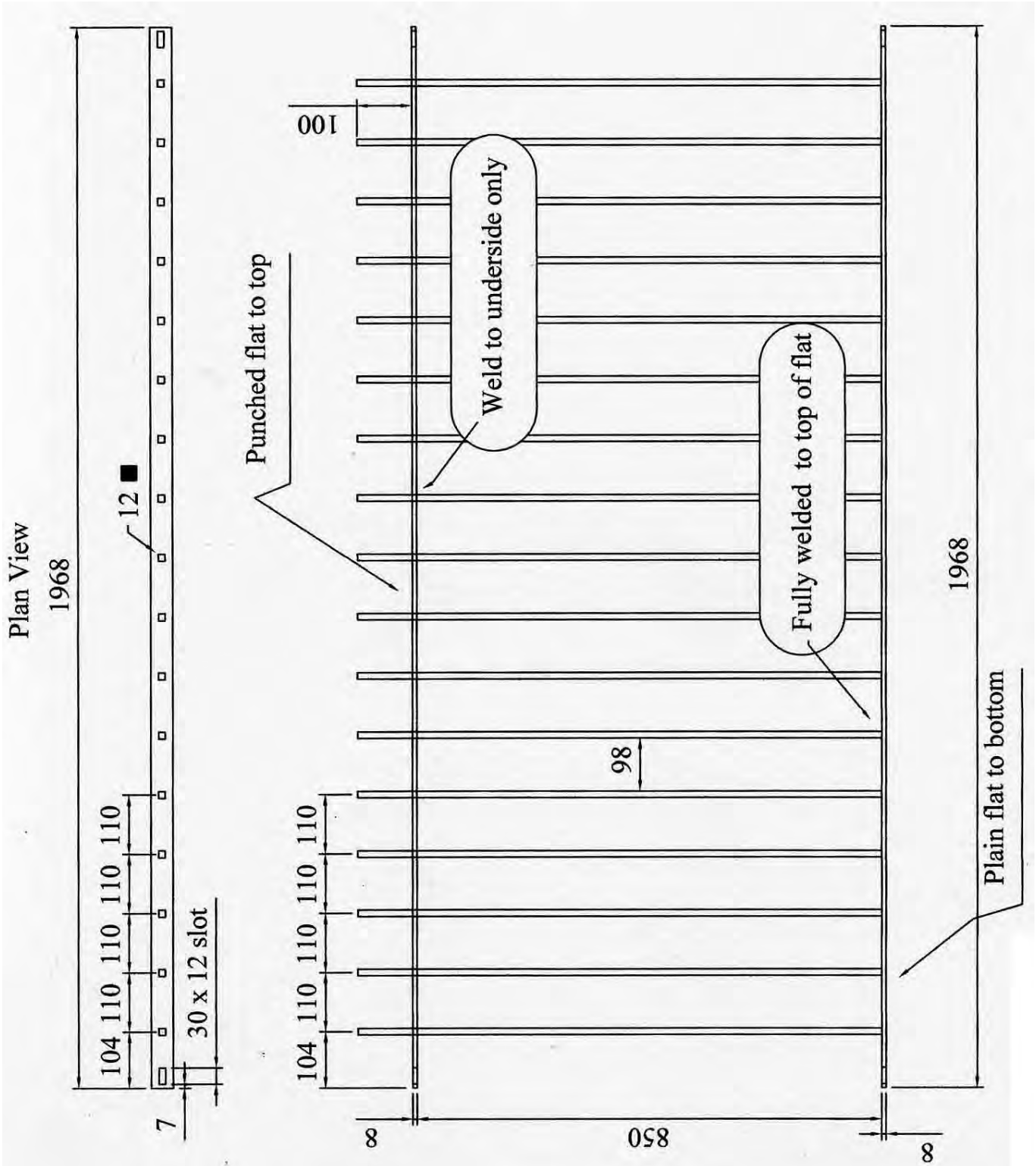

Product Code	Top & Bottom Rail	Type of Infill Bar	Price Per Panel	Primed with Red Oxide
PP-Opt4	40 x 8 flat	12mm Sq. infill bars		

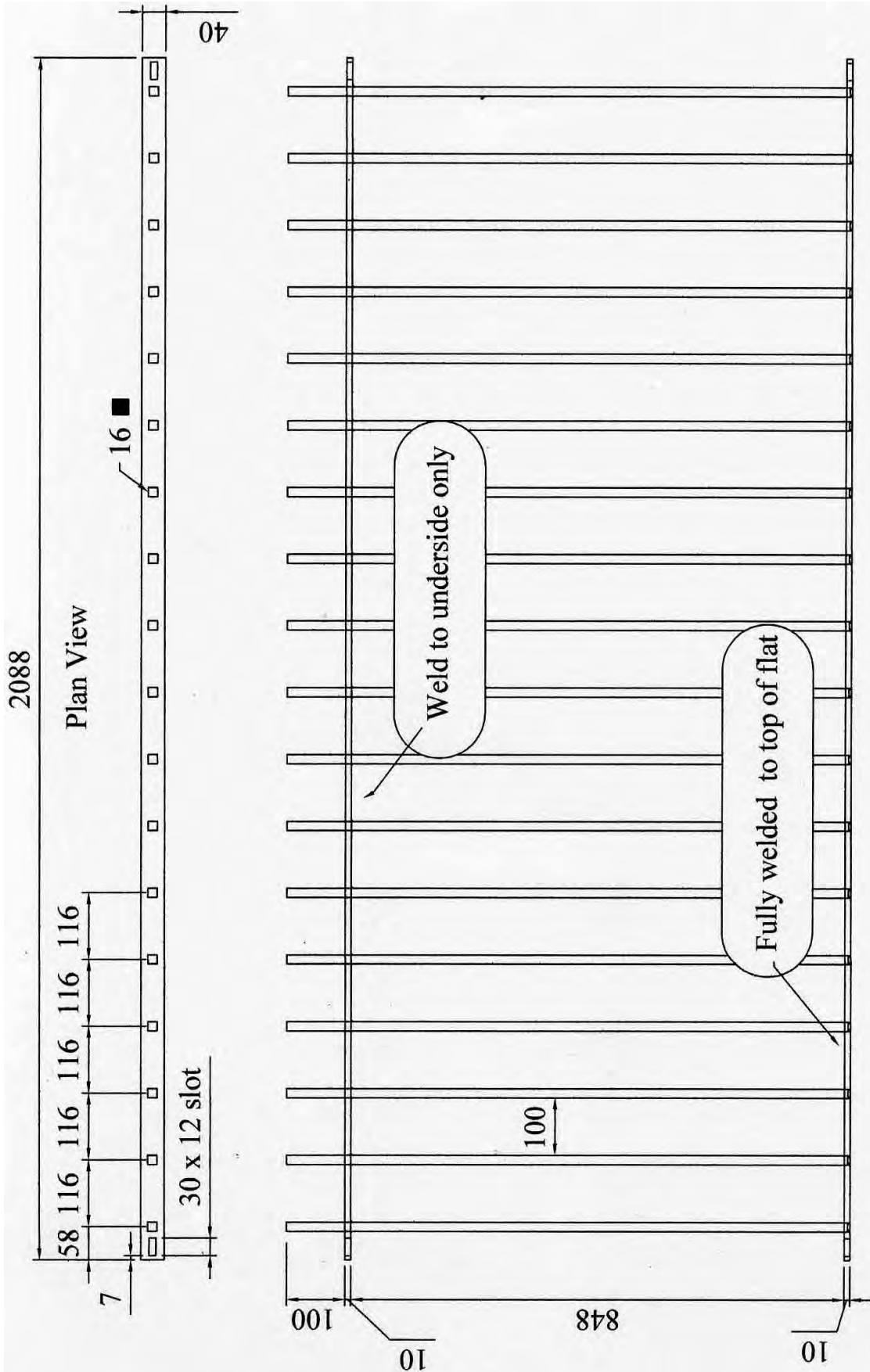

Product Code	Top & Bottom Rail	Type of Infill Bar	Price Per Panel	Primed with Red Oxide
PP-Opt:5	40 x 10 flat	16mm Sq. infill bars		

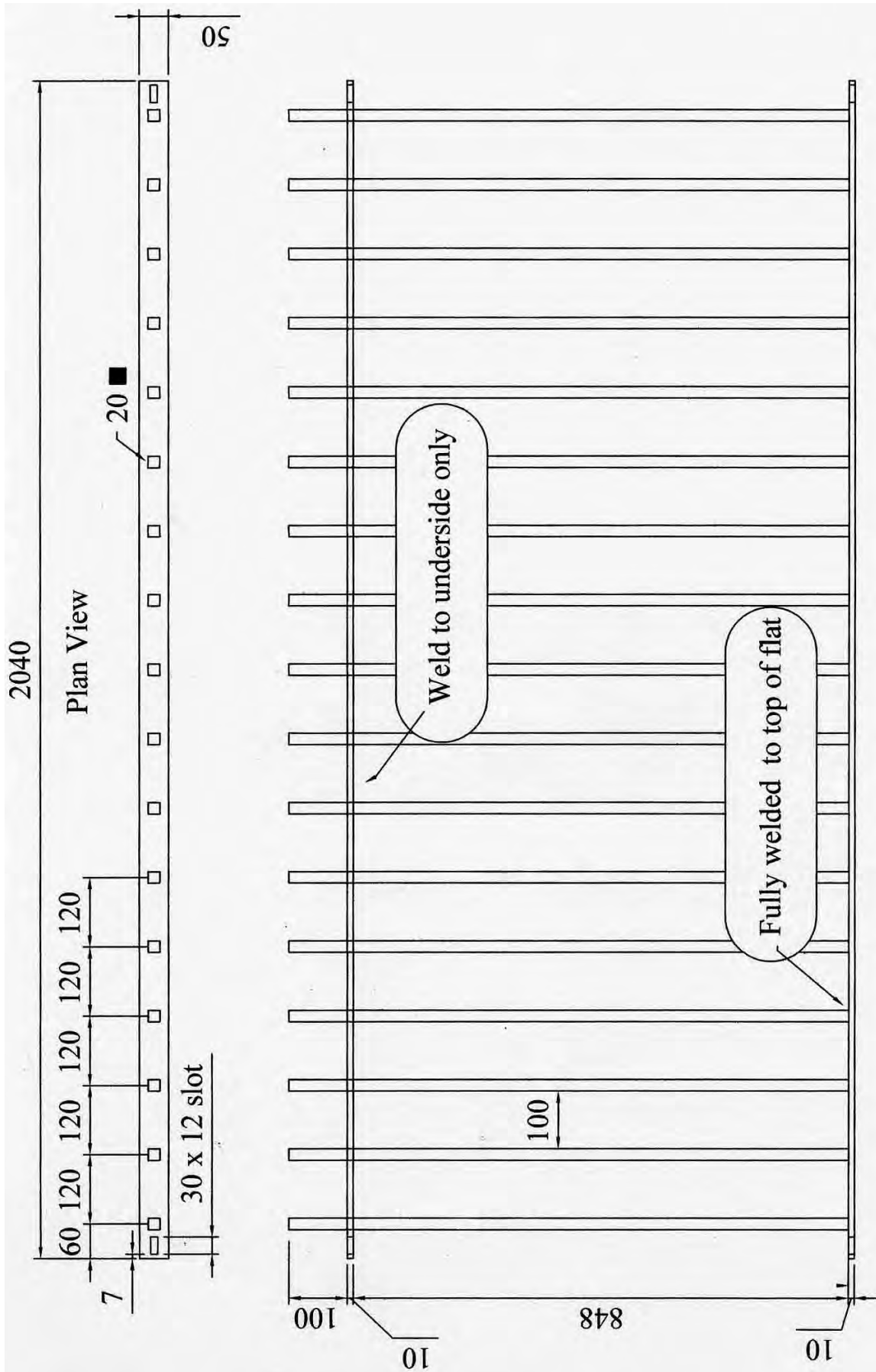

Product Code	Top & Bottom Rail	Type of Infill Bar	Price Per Panel	Primed with Red Oxide
PP-Opt6	50 x 10 flat	20mm Sq. infill bars		

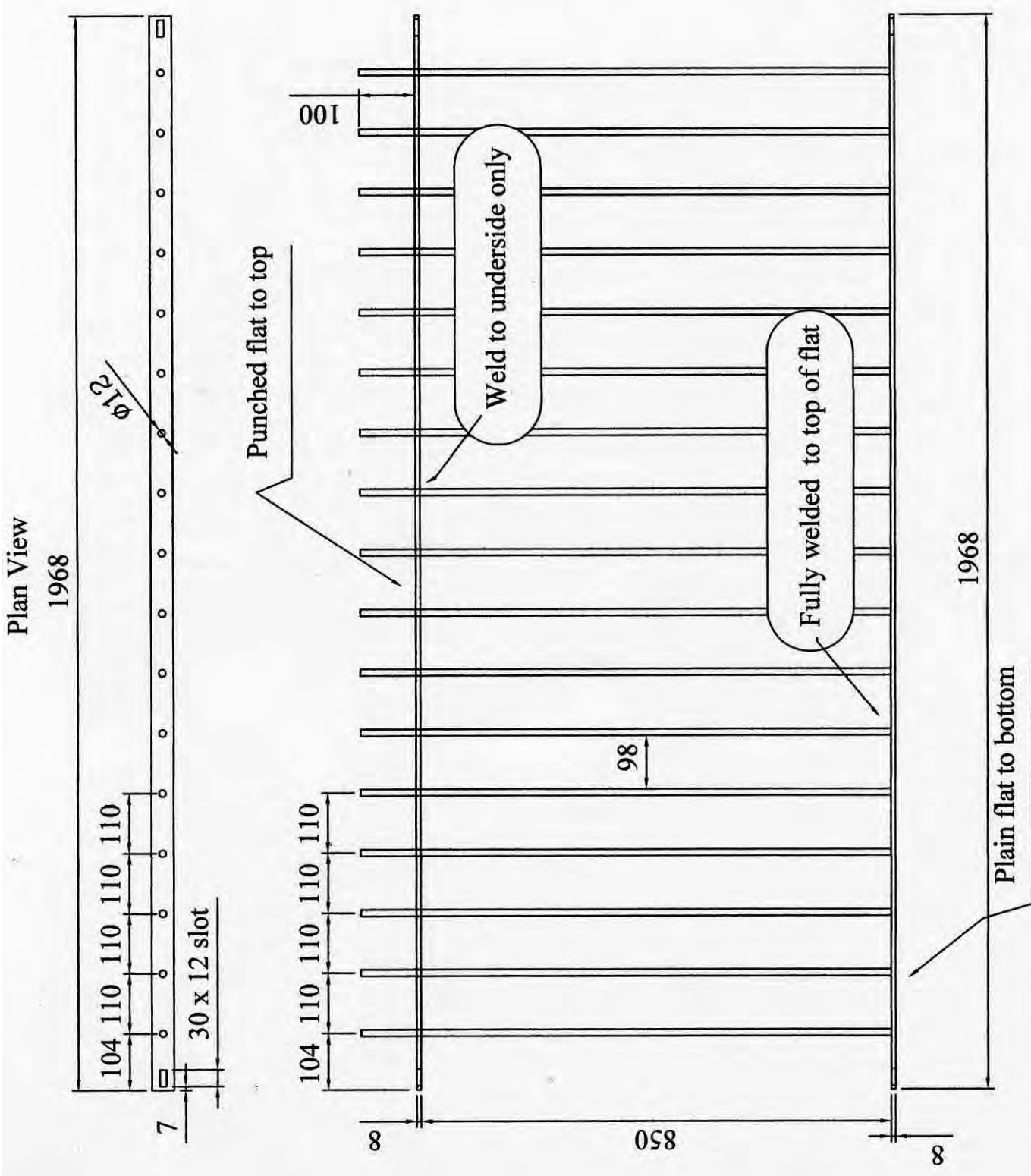

Product Code	Top & Bottom Rail	Type of Infill Bar	Price Per Panel	Primed with Red Oxide
PP-Opt7	40 x 8 flat	12mm ϕ infill bars		

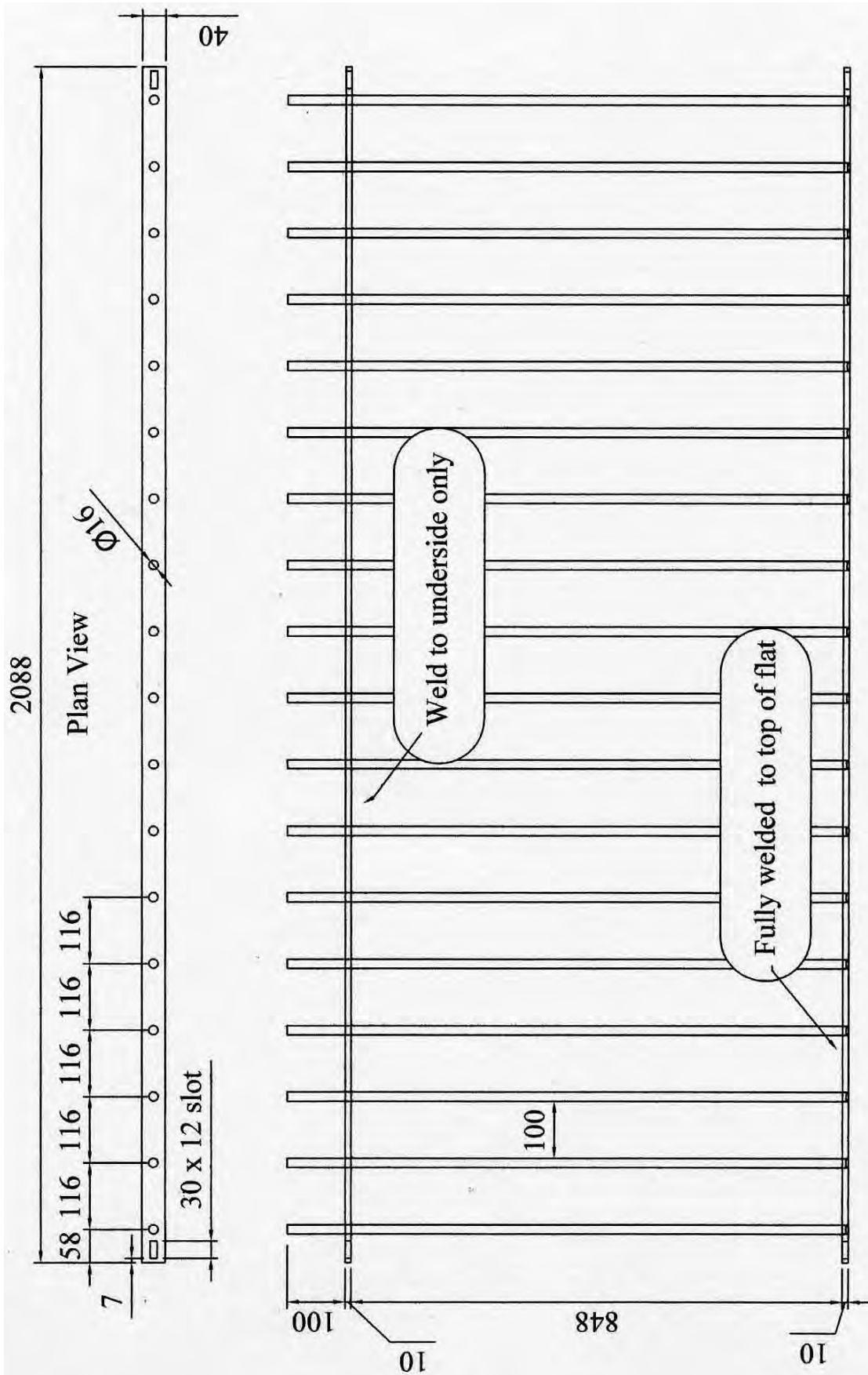

Product Code	Top & Bottom Rail	Type of Infill Bar	Price Per Panel	Primed with Red Oxide
PP-Opt8	40 x 10 flat	16mm \varnothing infill bars		

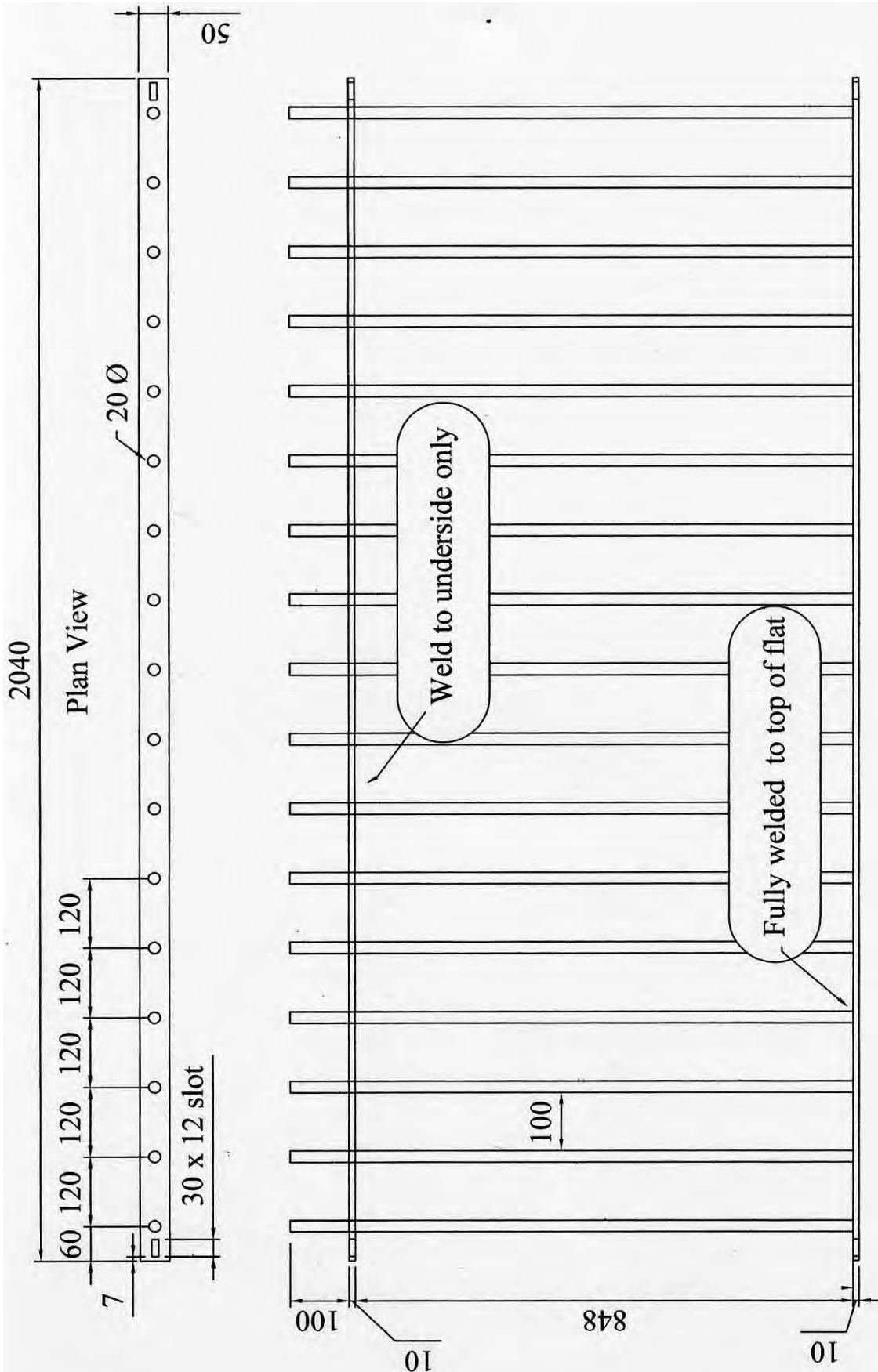

Product Code	Top & Bottom Rail	Type of Infill Bar	Price Per Panel	Primed with Red Oxide
PP-Opt9	50 x 10 flat	20mm Ø infill bars		

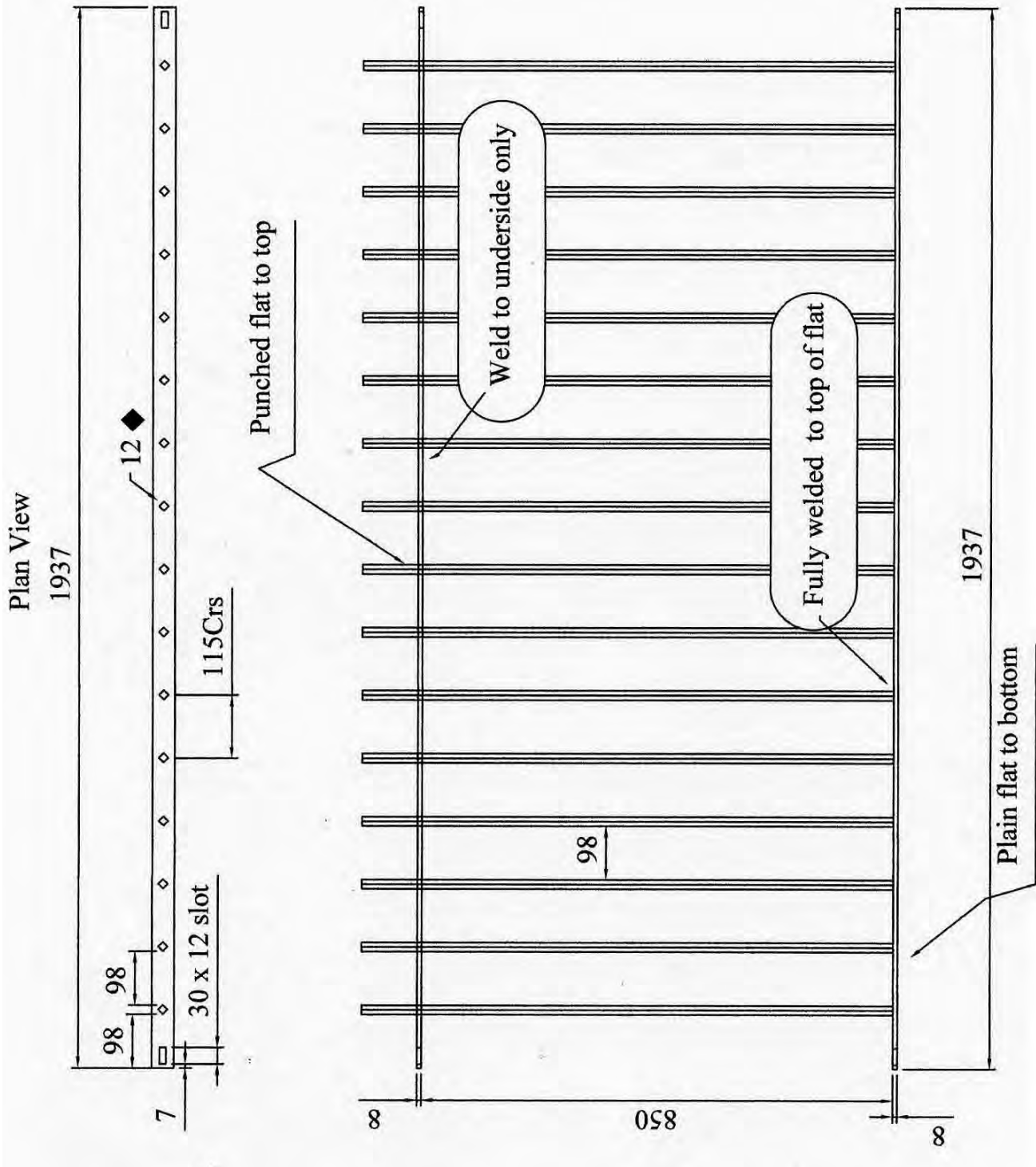

Product Code	Top & Bottom Rail	Type of Infill Bar	Price Per Panel	Primed with Red Oxide
PP-Opt10	40 x 8 flat	12mm infill bars set in diamond pattern		

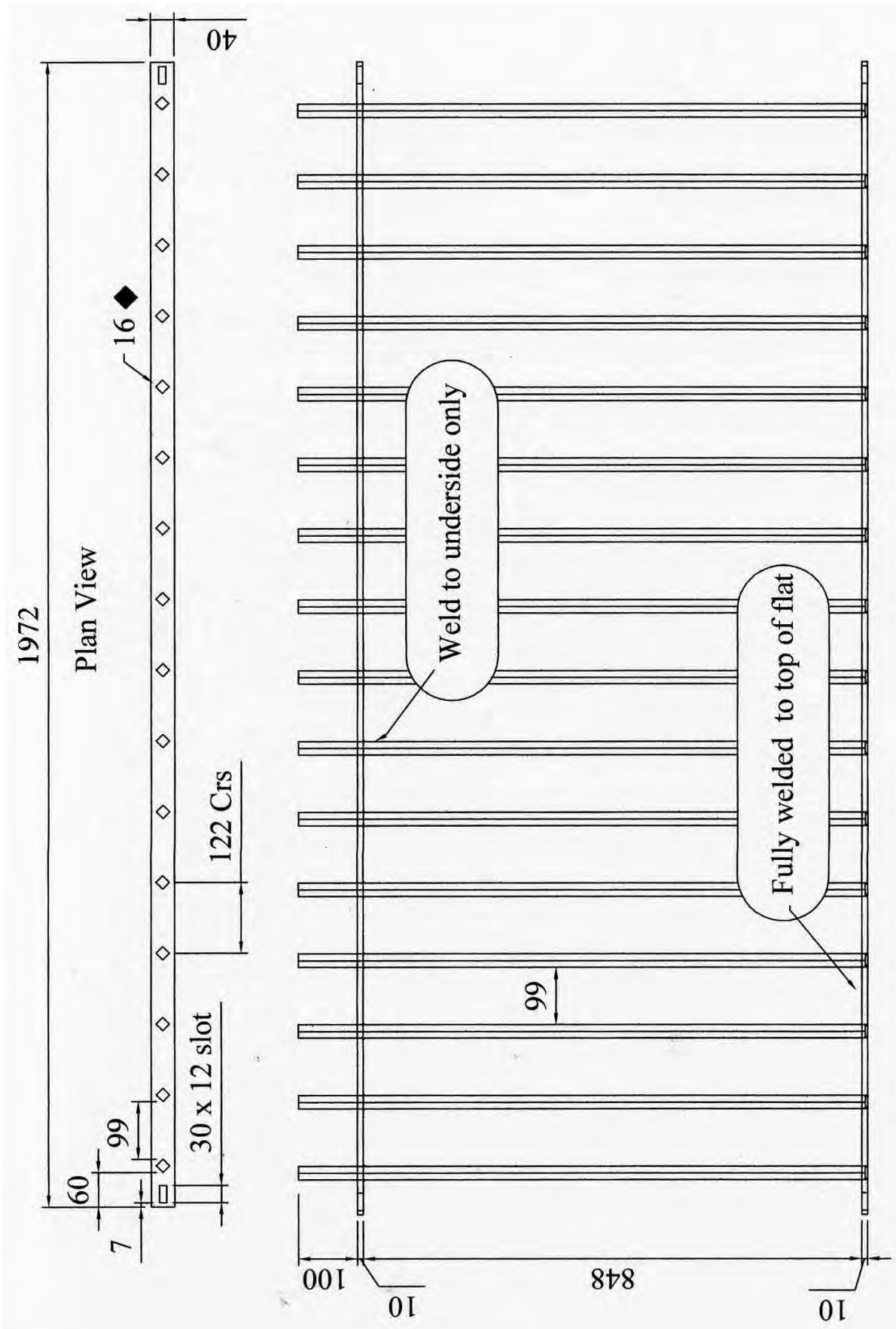

Product Code	Top & Bottom Rail	Type of Infill Bar	Price Per Panel	Primed with Red Oxide
PP-Opt11	40 x 10 flat	16mm Sq. infill bars set in diamond pattern		

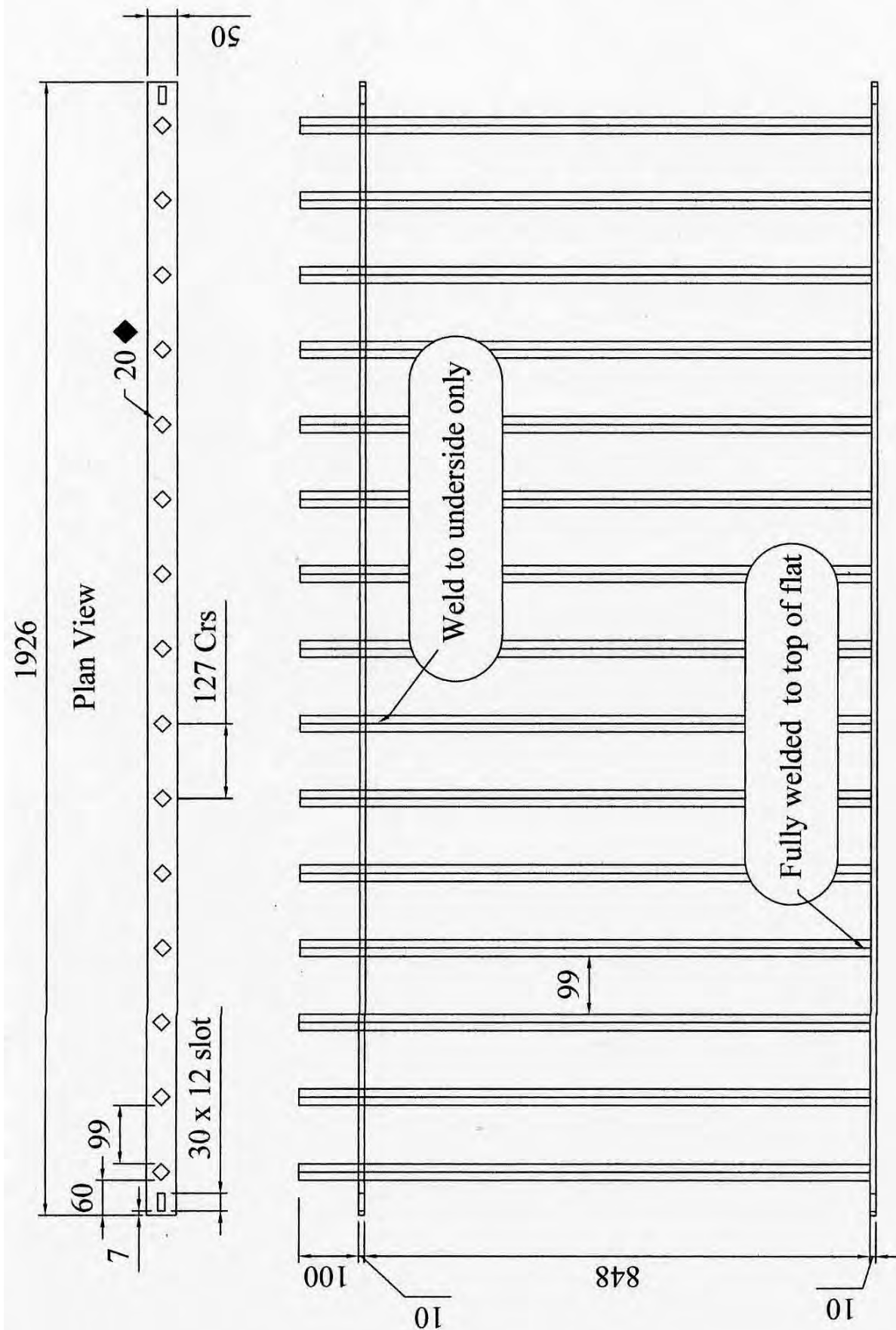

Product Code	Top & Bottom Rail	Type of Infill Bar	Price Per Panel	Primed with Red Oxide
PP-Opt12	50 x 10 flat	20mm Sq. infill bars set in diamond pattern		